

REV.	DESCRIPTION	DRAWN	CHECKED	APPROVED
A	NEW RELEASE	YCH 11/09/08'		

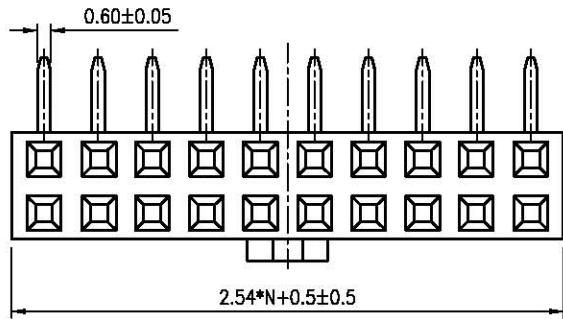

NOTES:

- ELECTRICAL CHARACTERISTICS:
 - CONTACT RESISTANCE: 30mΩ Max. INITIAL.
 - DIELECTRIC WITHSTANDING VOLTAGE: 500V AC(rms) FOR 1 MINUTE.
 - INSULATION RESISTANCE: 1000MΩ Min.
- ENVIRONMENT CHARACTERISTICS:
 - TEMPERATURE RANGE: -45°C~+110°C.
- PRODUCT NUMBER CODE:

DS1024-03- X X X

CONTACT PLATING
 8: FULL GOLD FLASH
 0: SECLECTIVE GOLD FLASH

MOUNTIING TYPE
 R: R/A TYPE

No.OF CONTACTS
 2*2-2*40

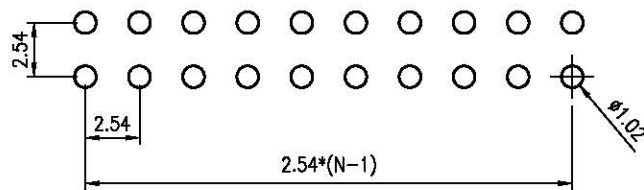
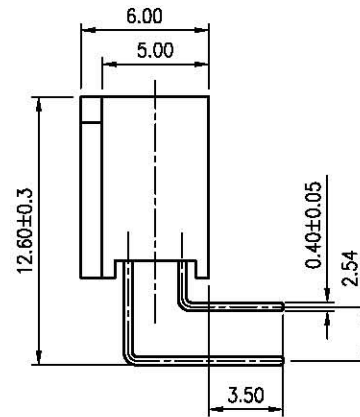
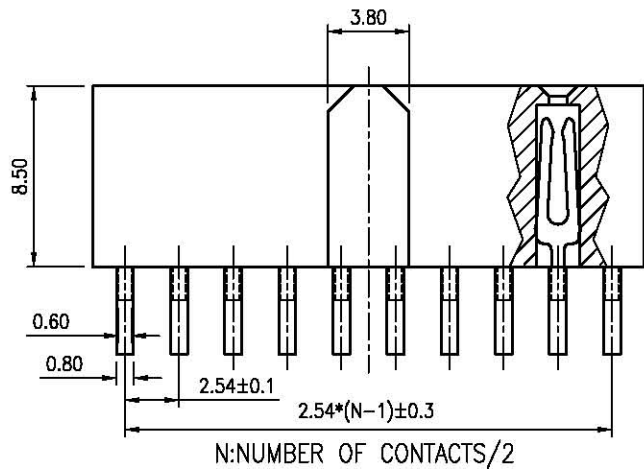

RECOMMEND PCB LAYOUT
 TOLERANCE=±0.05

GENERAL TOLERANCE		ANGLE TOLERANCE		PROJECTION		TITLE	FEMALE HEADER PITCH 2.54mm		
X.	±0.60	X.	±5°	UNITS	mm	SHEET SIZE	A4	SERIES	DS1024-03 SERIES
.X	±0.38	.X	±3°						
.XX	±0.25	.XX	±2°						
DRAWING TYPE		CUSTOMER							
SCALE		1:1	SHEET	1 OF 1					
DRAWING NO.		C-DS1024-03-XXX							